

Item	Qty.	Description
1,2,3,4	1,1,1,1	45" TSP46 Vertical Extrusion
5,6,7,8	1,1,1,1	45" TSP46 Horizontal Extrusion
9	2	Base Plate

**Setups:**

See TSP46 Assembly sheet for steps 1 thru 3.

- 1) Connect horizontals [5 to 6] and [7 to 8].
- 2) Connect verticals [1 to 2] and [3 to 4].
- 3) Connect horizontal and vertical assemblies together.
- 4) Attach base plates to verticals [1] and [3].  
See [Base Plate Attachment](#) detail.
- 5) Install SEG graphics to assembled frame. See SEG Installation sheet, for instruction.
- 6) Clamp lights to top of frame assembly. See [Light Connection](#) detail.

Attach base plate knob to extrusions [1] and [3], when packing.

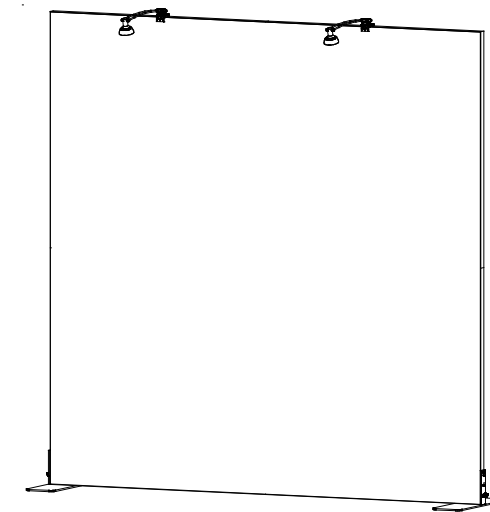
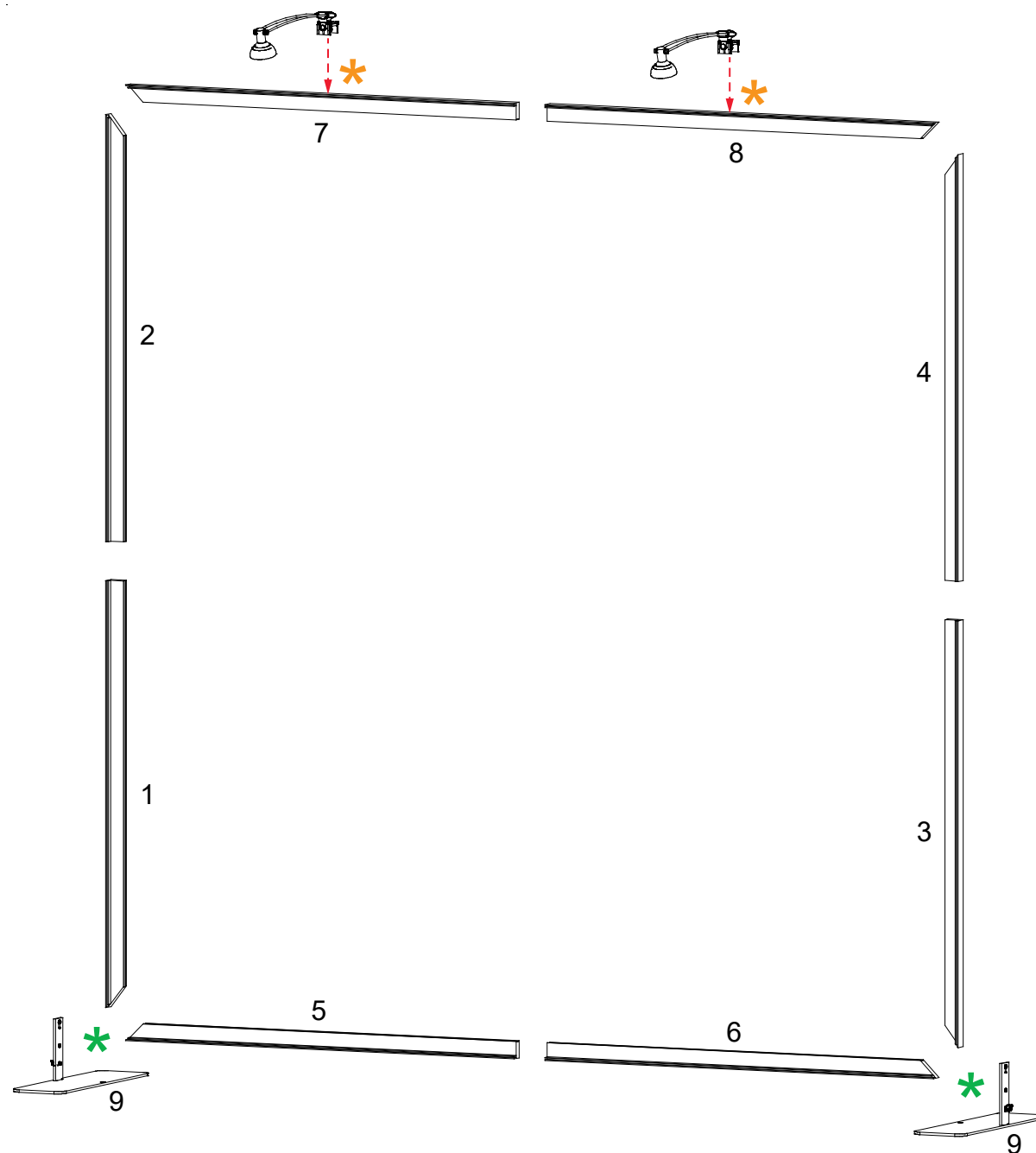
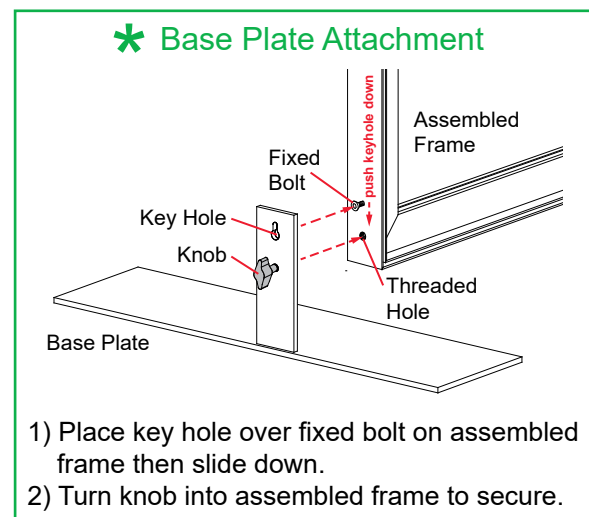

Completed Assembly

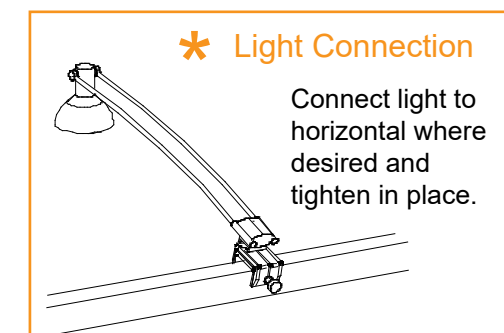

## Straight Connection

When assembling frame, first attach all **straight connectors**, then attach **corner connectors**.

- 1) Place extrusions end-to-end.
- 2) Loosen all knobs, then slide **straight connector** across the seam of extrusions.
- 3) Tighten all knobs to secure connection.

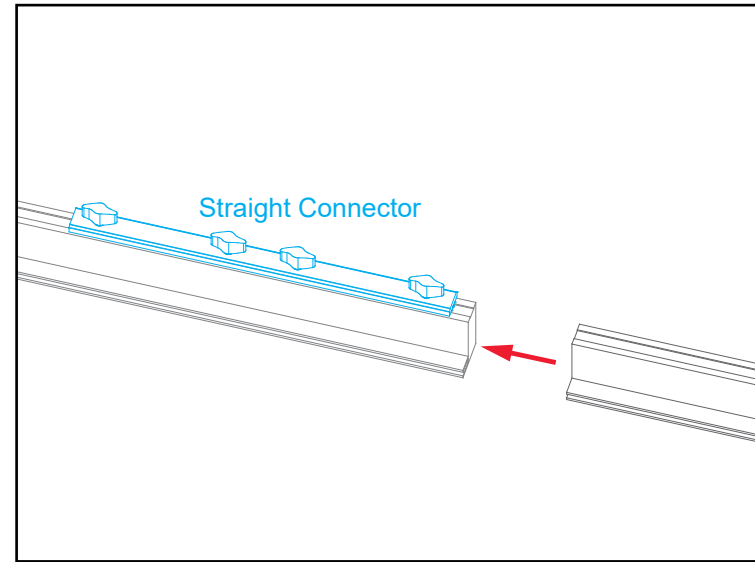

Slide connector across seam of extrusions.  
Tighten all knobs.

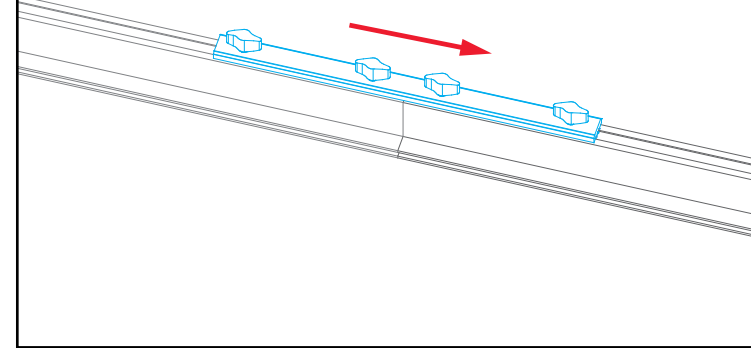

All knobs must be tightened securely to ensure a proper connection.

## Disassembly

- 1) Loosen all knobs.
- 2) Slide connectors off of one extrusion.
- 3) Tighten knobs to prevent loss during packing & shipping.

Keep straight connectors in groove of extrusion. Do not remove connectors during disassembly.

## Corner Connection

- 1) Loosen knobs, then slide vertical extrusions onto **corner connectors** of **lower** horizontal extrusion.
- 2) Slide **corner connectors** of **upper** horizontal extrusion into grooves of vertical extrusions.
- 3) Tighten all knobs to secure connection.

## Disassembly

- 1) Loosen knobs on vertical extrusions.
- 2) Slide the vertical extrusions off of **corner connectors** on lower and upper horizontal extrusions.

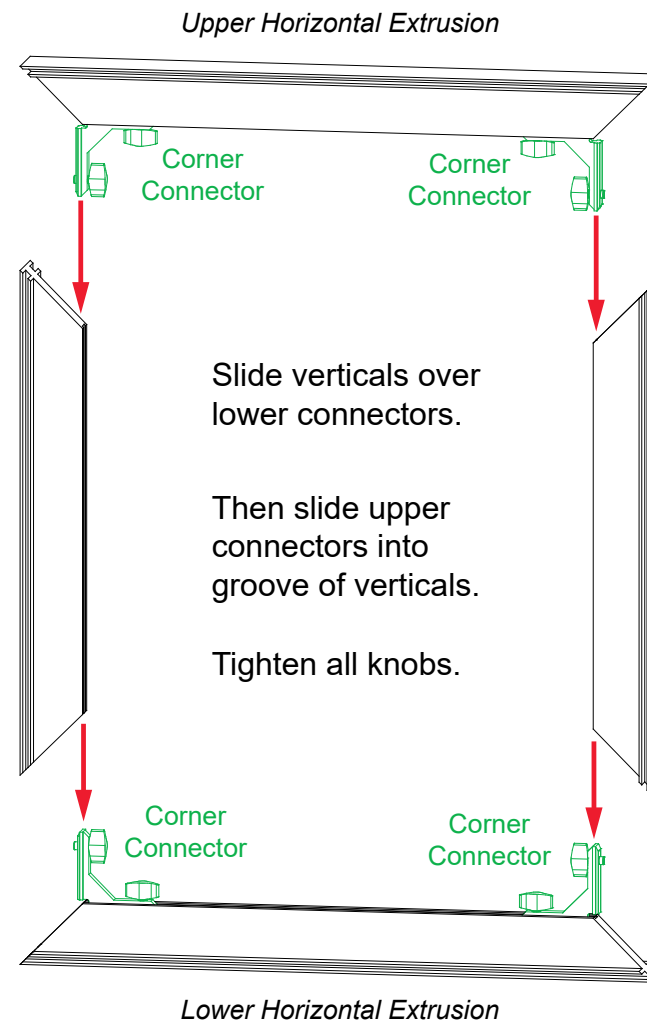

Adjust connectors if necessary to prevent gaps in connection.

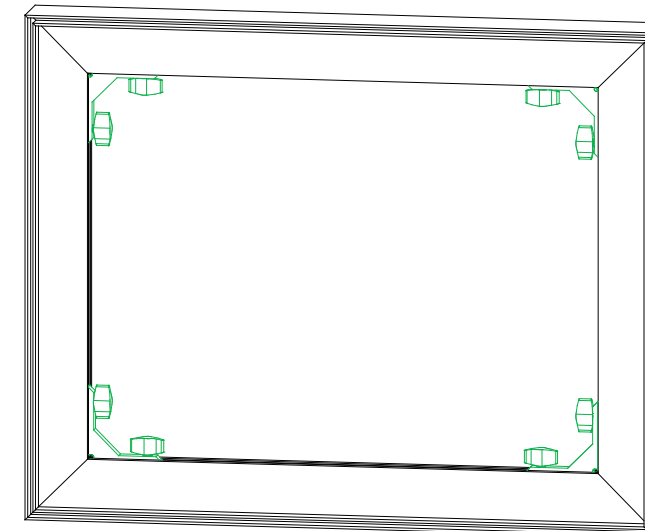

COMPLETED ASSEMBLY

All knobs must be tightened securely to ensure a proper connection.

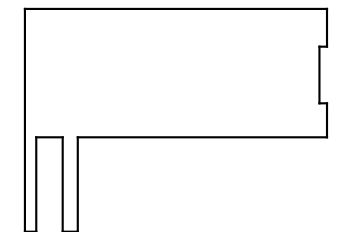

TSP46 Profile

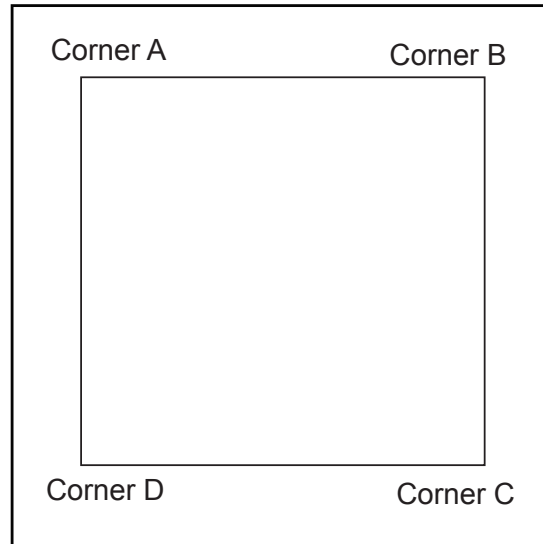

It is important to first insert graphic into each alternate corner then to the sides of the frame. If this is not done, graphic will not fit into the frame correctly.

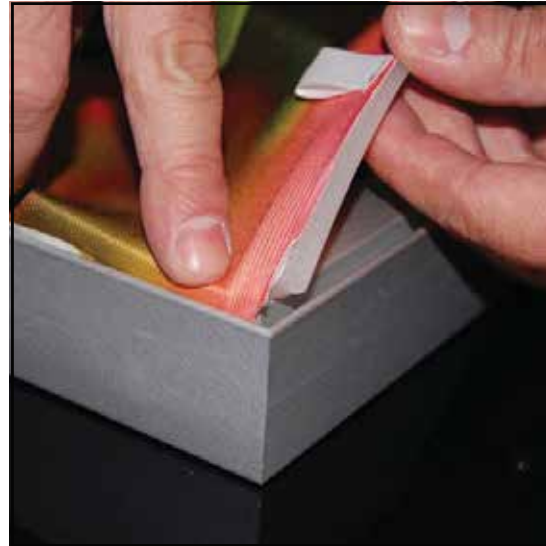

**Step 1**  
Insert corner A. Turn edge of graphic so silicon welt is perpendicular to face of graphic. Insert narrow side of welt with fabric to outside into the channel. Repeat for other side of this corner.



**Step 2**  
Repeat Step 1 for opposite corner C, then insert corner B, followed by corner D, to complete the installation of the corners.



**Step 3**  
Once all corners are inserted, press one silicon edge into channel from corners and work toward the center. Make sure welt is fully inserted into channel. Continue until all sides are done. Smooth out edges of graphic.

### Graphic Removal

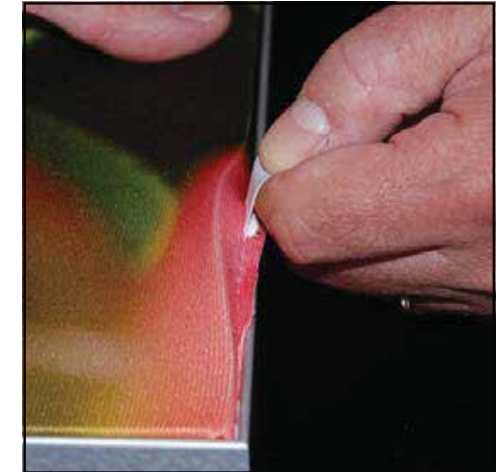

To remove the graphic from the frame, locate the fabric pull tab. Gently pull up on the tab to remove the fabric.

### Top View of Each Level

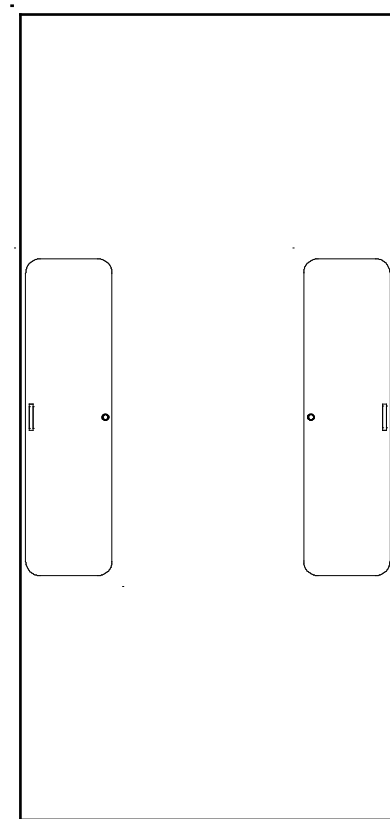

Level 1 (Bottom Level)

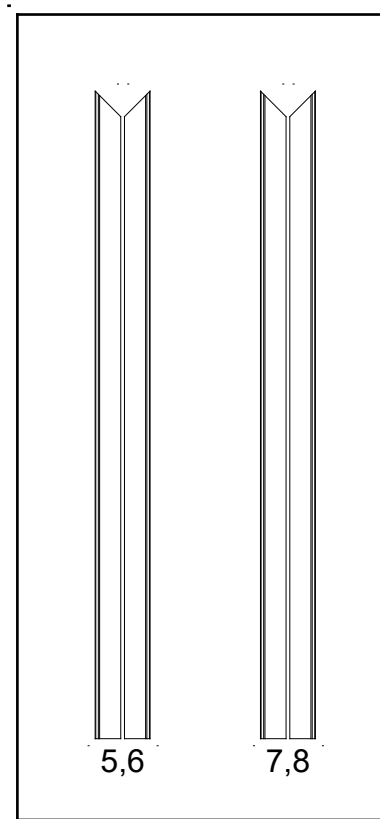

Level 2

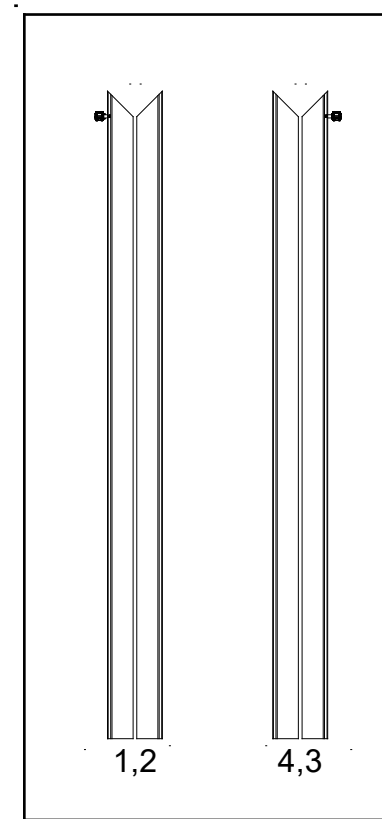

Level 3

